

Surpass GCR-25AP300P-HP2 regulator

FEATURES

- Air-operated 1" constant-pressure control valve designed exclusively for pure water applications.
- This model is suitable for controlling high flow rates.

SPECIFICATIONS

Type	GCR-25AP300P-HP2
Fluids	DI water
Flow range	15-60L/min
Inlet pressure range	100-500kPa
Outlet pressure range	50-400kPa *Depending on certain conditions
Whitstanding pressure	600kPa
Pilot pressure range	Max. 400kPa
Fluid temperature	10-50°C
Ambient temperature	10-40°C
Wetted parts	PTFE
Tube size	1" (Ø25.4xØ22.2)
Connection size	Pillar fitting
Pilot port	Rc1/8



DIMENSIONS

- GCR-25AP300P-HP2

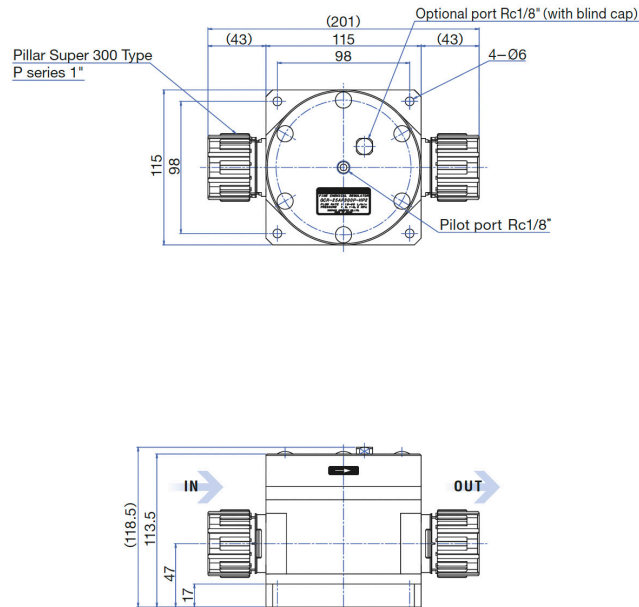

SPECIAL INSTRUCTIONS

- Leak rate of valve seat is less than 1mL/min. (water pressure)
- The regulator does not have shut-off function. (It is not design to be completely closed.)
- In case selling products with inner diameters of more than 10mm to a specific country or region, It is required an export license from the Ministry of Economy, Trade and Industry.