

VACUUM SEALER 600 MM

The WHS-B-S600M is a reliable vacuum sealer designed for sealing moisture barrier bags, ensuring your products are securely protected from contamination and moisture during shipping. Its durable stainless-steel construction, with table, easy-to-use controls, and foot pedal operation ensure efficient and reliable performance.

KEY FEATURES AND BENEFITS

Precision and durability

- Advanced HMI panel ensures precise sealing.
- Stainless steel construction for lasting performance.
- Double Hot Wire sealing bar for consistent, high-strength seals.
- Open housing design enhances heat dissipation for cooler, longer-lasting operation.

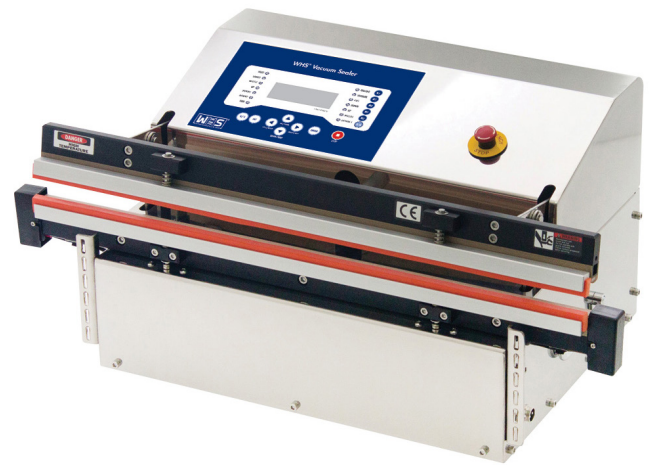

Operator convenience

- Multiple cycle modes (M1-M5) and specific modes for sealing (S) or vacuum-sealing (V).
- LCD displays real-time vacuum levels.
- Foot pedal allows hands-free bag positioning.

Safety and maintenance

- Key lock prevents unauthorized adjustments.
- Nozzle retracts after 60 seconds of inactivity.
- Sealing bar lifts 2 seconds after sealing.
- Safety sensor detects obstructions and lifts the bar immediately.
- Circuit-protection fuses prevent electrical overloads.
- Real-time diagnostics for quick troubleshooting.

WHY CHOOSE THE WHS-B-S600M?

The WHS-B-S600M stands out for its exceptional reliability, user-friendliness, and precision. It ensures secure vacuum sealing of moisture barrier bags, protecting your valuable products from moisture and contamination during transport. With its advanced features and robust construction, it is a trusted choice for industries that demand high-quality sealing results.

VACUUM SEALER 600 MM

ITEM	SPECIFICATIONS
Construction material	Stainless Steel
Weight	29 kg
Sealing length	600 mm
Sealing width	5 mm or 10 mm
Vacuum	Generated by a vacuum pump
Max vacuum strength	Up to 80 kPa
Vacuum control	Adjustable by vacuum level (kPa) or time (seconds)
Gas flushing	Timer-controlled for precise gas replacement
Power supply	1-phase, 110/220 V, 50/60 Hz

ORDERING INFORMATION

WHS-B-	S600M
CODE	MODEL
S600M	Vacuum sealer 600 mm incl. table, gas flushing function and double hot wire sealing bar

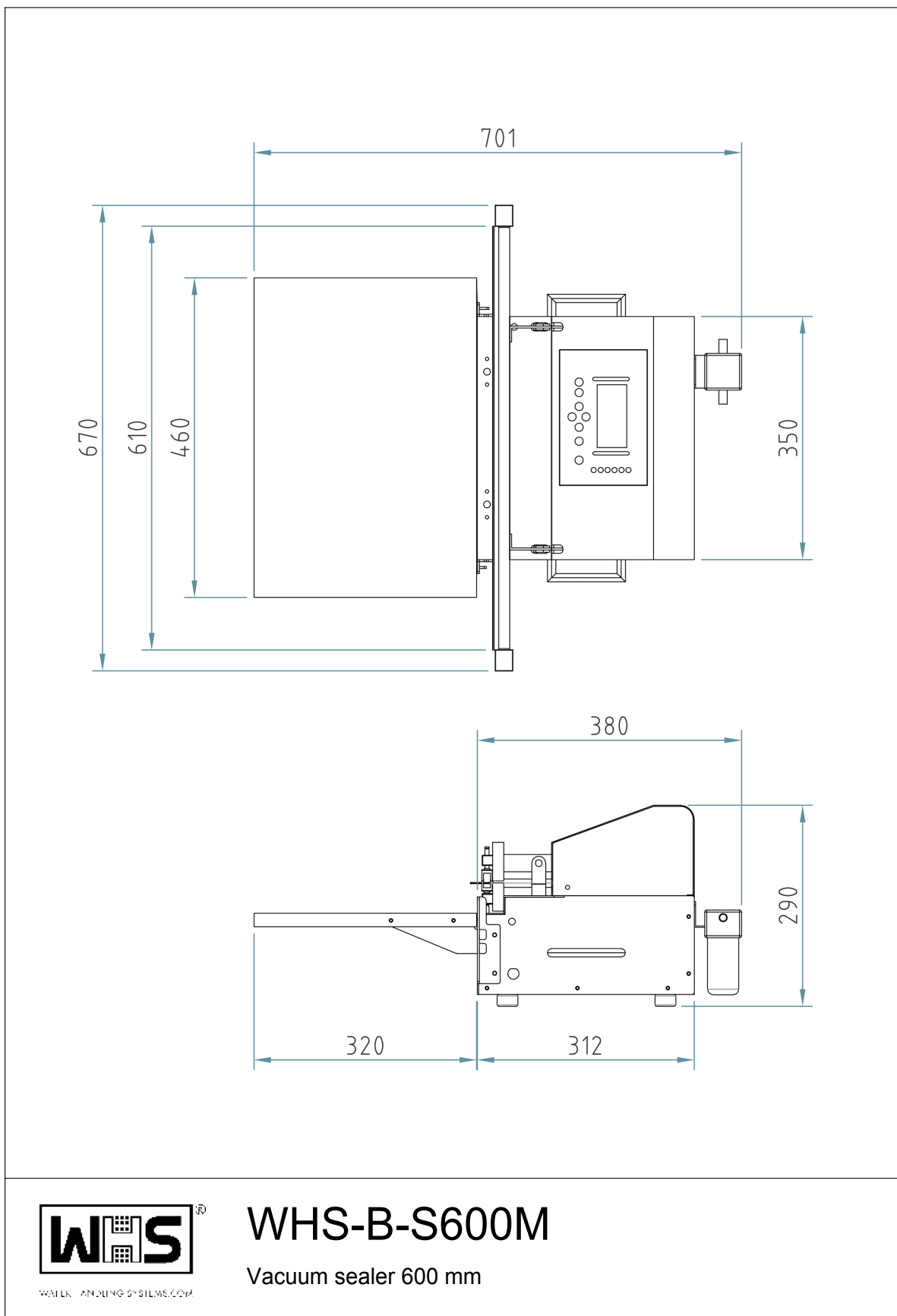

WHS-B-S600M

Vacuum sealer 600 mm

scale: 1:5 | entity: mm | This drawing is owned by WHS trademark and may not be copied, reproduced or shown to third parties without written permission.

26-REV1