

VACUUM SEALER 1000 MM

The WHS-B-S1000E is a high-capacity vacuum sealer designed for demanding industrial and food applications. Featuring dual hot wires on both sealing bars, with table robust stainless-steel construction, and a 1000 mm sealing length, it ensures airtight protection for moisture-sensitive products. Ideal for heavy-duty operations requiring precision and scalability.

KEY FEATURES AND BENEFITS

Precision and durability

- Advanced HMI panel ensures precise sealing.
- Stainless steel construction for lasting performance.
- Double Hot Wire sealing bar for consistent, high-strength seals.
- Open housing design enhances heat dissipation for cooler, longer-lasting operation.



Operator convenience

- Multiple cycle modes (M1–M5) and specific modes for sealing (S) or vacuum-sealing (V).
- LCD displays real-time vacuum levels.
- Adjustable nozzle depth for versatile bag insertion.
- Foot pedal allows hands-free bag positioning.

Safety and maintenance

- Key lock prevents unauthorized adjustments.
- Nozzle retracts after 60 seconds of inactivity.
- Sealing bar lifts 2 seconds after sealing.
- Safety sensor detects obstructions and lifts the bar immediately.
- Circuit-protection fuses prevent electrical overloads.
- Real-time diagnostics for quick troubleshooting.

WHY CHOOSE THE WHS-B-S1000E?

The WHS-B-S1000E stands out for its exceptional reliability, user-friendliness, and precision. Its dual hot wire sealing bars and adjustable nozzle depth ensure secure packaging for large or irregularly shaped products. With energy-efficient pneumatic operation and real-time diagnostics, it minimizes downtime while maximizing productivity.

VACUUM SEALER 1000 MM

ITEM	SPECIFICATIONS
Construction material	Stainless Steel
Weight	66 kg
Sealing length	1000 mm
Sealing width	5 mm or 10 mm
Vacuum	Pneumatic ejector system (compressed air)
Max vacuum strength	75–80 kPa
Vacuum control	Adjustable by vacuum level (kPa) or time (seconds)
Gas flushing	Timer-controlled for precise gas replacement (Gas flushing is optional)
Compressed Air	5–7 kgf/cm ² (required)
Power supply	1/3-phase, 220/380 V, 50/60 Hz

ORDERING INFORMATION

WHS-B-	S1000E
CODE	MODEL
S1000E	Vacuum sealer 1000 mm incl. table, gas flushing function and double hot wire sealing bar

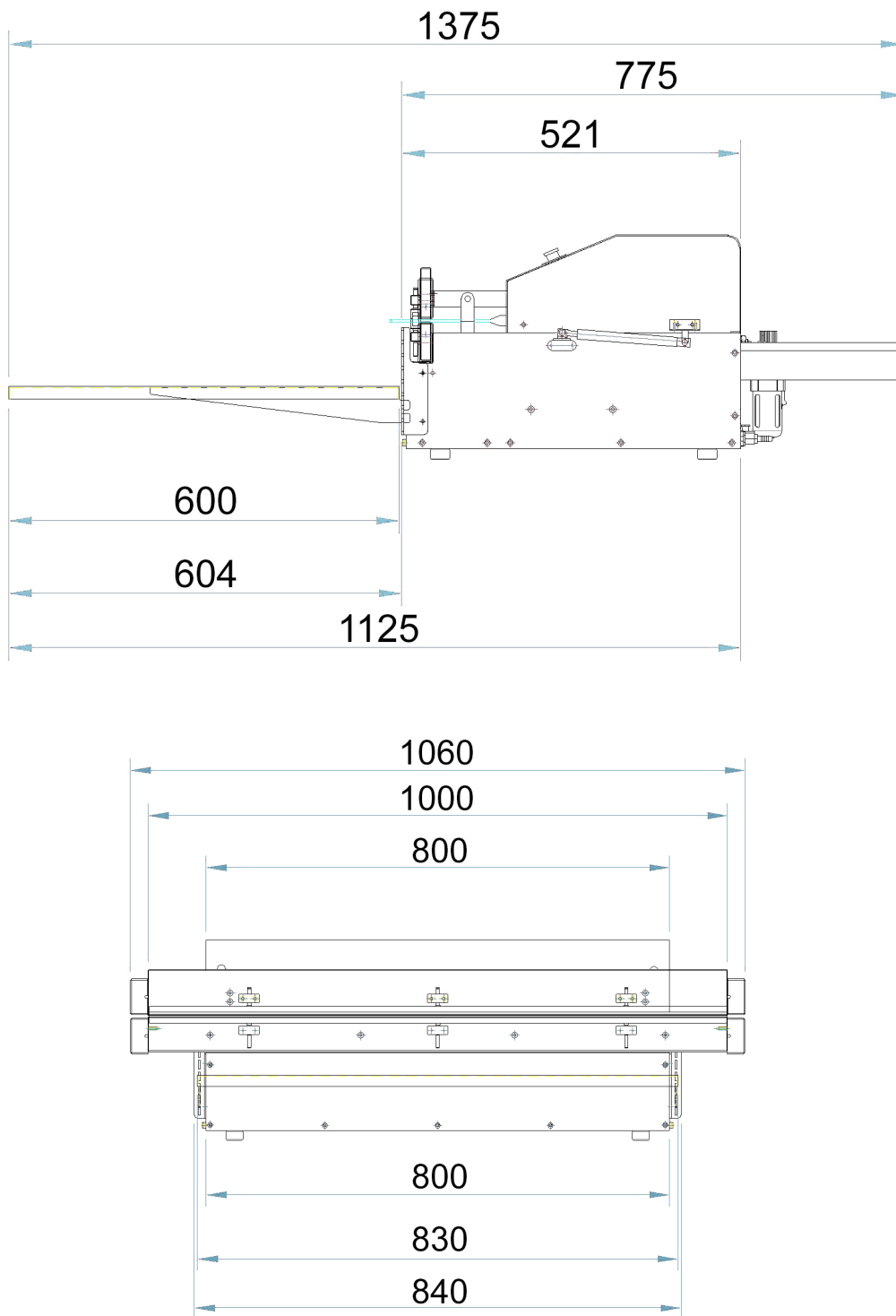

www.waferhandling-systems.com

WHS-B-S1000E

Vacuum sealer 1000 mm

scale: 1:5 | entity: mm | This drawing is owned by WHS trademark and may not be copied, reproduced or shown to third parties without written permission.

REV012025